

Center–Center

≡ center
center

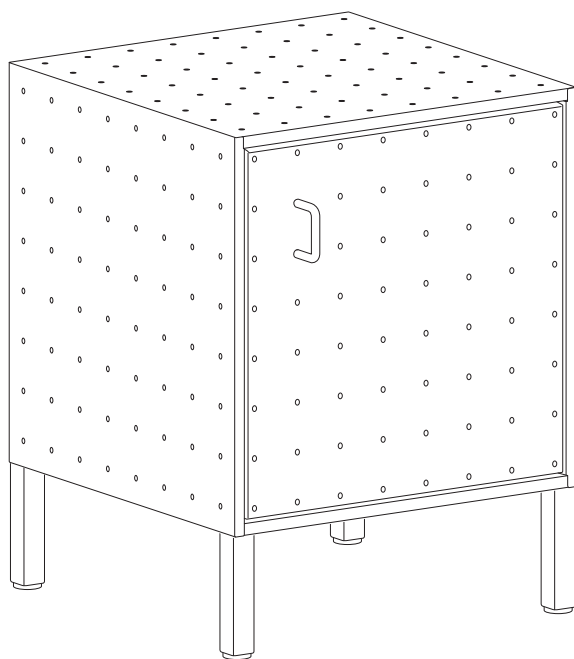

Scan QR code to watch or download assembly instructions.
Made in Sweden. stringfurniture.com

Contents

Assemble door / adjust door	5
Assemble push opener	7
Assemble shelf	9
Assemble leg	11
Assemble connecting leg	13
Assemble wheel	16
Assemble connecting wheel	16
Assemble rubber pads	18
Assemble U-handle	19
Assemble hook	20
Assemble external shelf	21
Assemble tray	23
Connect modules – example	25
Anti-tip kit	35
Wall mount kit	37

コンテンツ

扉の取り付けと調整	5
プッシュオープナーの取り付け	7
シェルフの設置	9
レッグの取り付け	11
コネクティングレッグの取り付け	13
キャスターの取り付け	16
コネクティングキャスターの取り付け	16
ラバーパッドの取り付け	18
Uハンドルの取り付け	19
フックの取り付け	20
エクスターナルシェルフの取り付け	21
トレイの取り付け	23
モジュールの連結方法	25
転倒防止	35
壁付け	37

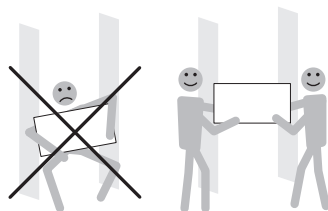

Do not use an electric screwdriver to assemble.
電動ドライバーは使用しないでください。

Svenska

Detta är en produkt tillverkad av det svenska designföretaget String Furniture AB.

VARNING

Om förvaringsmöbelen tipsar eller faller ner från väggen kan kläm-, sak- eller personskador uppstå. Undvik att förvaringsmöbelen tipsar eller faller genom att säkerställa att den sitter ordentligt förankrad i väggen med hjälp av skruvar och/eller pluggar som lämpar sig för väggens material. Följ dessutom monteringsanvisningen noga vid montering av förvaringsmöbelen.

För råd om lämpliga skruvsystem kontakta din lokala fackhandlare.

Viktrekommendation - Modul

B: 60cm D: 40cm H: 60 cm – max. 72 kg jämnt fördelad last

B: 40cm D: 40cm H: 60 cm – max. 72 kg jämnt fördelad last

B: 40cm D: 40cm H: 30 cm – max. 36 kg jämnt fördelad last

B: 60cm D: 40cm H: 40 cm – max. 72 kg jämnt fördelad last

B: 40cm D: 40cm H: 40 cm – max. 36 kg jämnt fördelad last

B: 30cm D: 40cm H: 40 cm – max. 36 kg jämnt fördelad last

Viktrekommendation – Hyllplan

60 cm brett hyllplan: max. 17 kg jämnt fördelad last

30 cm brett hyllplan: max. 8 kg jämnt fördelad last

40 cm brett hyllplan: max. 11 kg jämnt fördelad last

För bricka eller utvändig hylla rekommenderas max. 6 kg jämnt fördelad last.

För krok rekommenderas max. 2 kg last.

English

This is a product manufactured by the Swedish design company String Furniture AB.

CAUTION

If the storage unit tips over or falls off the wall, crushing, damage to property or personal injury can occur. Prevent the storage unit from tipping or falling by keeping it permanently fixed to the wall using screws and/or plugs designed for your wall material and follow the assembly instructions carefully when mounting the storage unit.

Get advice on suitable screw system from your local specialized dealer.

Weight recommendation – Module

W: 60 cm D: 40 cm H: 60 cm – max. 72 kg evenly spread

W: 60 cm D: 40 cm H: 40 cm – max. 72 kg evenly spread

W: 30 cm D: 40 cm H: 40 cm – max. 36 kg evenly spread

W: 40 cm D: 40 cm H: 60 cm – max. 72 kg evenly spread

W: 40 cm D: 40 cm H: 40 cm – max. 36 kg evenly spread

W: 40 cm D: 40 cm H: 30 cm – max. 36 kg evenly spread

Weight recommendation – Shelf

60 cm wide shelf: max. 17 kg evenly spread

30 cm wide shelf: max. 8 kg evenly spread

40 cm wide shelf: max. 11 kg evenly spread

For tray and external shelf, we recommend max. 6 kg evenly spread load.

For hook, we recommend max. 2 kg load.

Deutsch

Dieses Produkt ist von der schwedischen Designfirma String Furniture AB hergestellt.

ACHTUNG

Wenn die Aufbewahrungseinheit umkippt oder von der Wand fällt, kann es zu Quetschungen, Sach- oder Personenschäden kommen. Verhindern Sie ein Umkippen oder Herabfallen der Aufbewahrungseinheit, indem Sie eine permanente Wandbefestigung mit Schrauben und/oder Dübeln wählen, die für das Material Ihrer Wand geeignet sind, und befolgen Sie bei der Montage sorgfältig die Montageanleitung.

Lassen Sie sich von Ihrem Fachhändler vor Ort über das geeignete Schraubensystem beraten.

Empfohlene maximale Belastung - Modul

B: 60 cm T: 40 cm H: 60 cm – max. 72 kg, gleichmäßig verteilt

B: 40 cm T: 40 cm H: 60 cm – max. 72 kg, gleichmäßig verteilt

B: 40 cm T: 40 cm H: 30 cm – max. 36 kg, gleichmäßig verteilt

B: 60 cm T: 40 cm H: 40 cm – max. 72 kg, gleichmäßig verteilt

B: 40 cm T: 40 cm H: 40 cm – max. 36 kg, gleichmäßig verteilt

B: 30 cm T: 40 cm H: 40 cm – max. 36 kg, gleichmäßig verteilt

Empfohlene maximale Belastung – Regal

60 cm breites Regal: max. 17 kg, gleichmäßig verteilt

30 cm breites Regal: max. 8 kg, gleichmäßig verteilt

40 cm breites Regal: max. 11 kg, gleichmäßig verteilt

Für das Tablett und Außenregal empfehlen wir max. 6 kg gleichmäßig verteilte Last.

Für den Haken empfehlen wir max. 2 kg Last.

日本語

これはスウェーデンのデザイン会社String Furniture ABが製造した製品です。

注意

収納ユニットが転倒したり、壁から落ちたりすることで、破損したり、物的な損害や人身事故につながる場合があります。収納ユニットの転倒や落下を防ぐために、設置する壁材に適合したネジやプラグを使用し、壁面に収納ユニットをしっかりと固定してください。組み立て説明書の指示に従いながら注意深く設置してください。ご不明な点については取り扱い店にお問い合わせください。

推奨耐荷重 - モジュール

W60xD40xH60cm: 72kg W60xD40xH40cm: 72kg

W40xD40xH60cm: 72kg W40xD40xH40cm: 36kg

W40xD40xH30cm: 36kg W30xD40xH40cm: 36kg

推奨耐荷重 - シェルフ

W60cm: 17kg

W40cm: 11kg

W30cm: 8kg

トレイとエクスターナルシェルフの耐荷重をご参照ください。耐荷重は6 kgです。荷重を均等にしてお使いください。

フックの耐荷重をご参照ください。耐荷重は2 kgです。

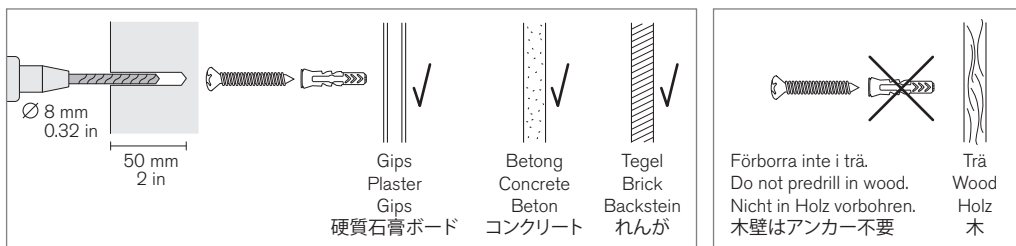

Svenska

Beslagen som medföljer är avsedda för montering i väggar av god kvalitet. Skruvarna är avsedda för montering, utan plugg, i träbaserade väggskivor. Om väggarna är gjorda av gips, betong eller tegel så används den inkluderade pluggen med samma skruv. Vid minsta osäkerhet, eller om väggarna är gjorda av annat material, kontakta din lokala specialiserade återförsäljare för val av lämplig skruv och plugg för uppsättningen.

English

The brackets supplied are designed for mounting on high-quality walls. The screws are designed for installation without plugs in wood-based wall panels. If the walls are made of plaster, concrete or brick, a plug must be used with the screw. If in the slightest doubt or if the walls are made of a different material, contact your local specialist dealer for a suitable screw and plug for the set.

Deutsch

Der mitgelieferte Beschlag ist für die Montage an hochwertigen Wänden vorgesehen. Die Schrauben sind für die Montage in Wänden aus Holz ohne Dübel vorgesehen. Wenn die Wände aus Gips, Beton oder Ziegeln bestehen, muss der mitgelieferte Dübel mit der gleichen Schraube verwendet werden. Bei der geringsten Unsicherheit oder wenn die Wände aus anderen Materialien gefertigt wurden, wenden Sie sich an Ihren Fachhändler vor Ort, um die passenden Schrauben und Dübel für das Set auszuwählen.

日本語

付属のアンカーは硬質石膏ボード、コンクリート、レンガに適合しています。一般的な日本の石膏ボードに取り付ける際は、プラスドライバーだけで簡単に取り付けできる下穴不要の石膏ボード専用アンカーを使用してください。詳しくは販売店へお問い合わせください。

Assemble door / adjust door
扉の取り付けと調整

1

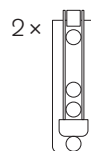
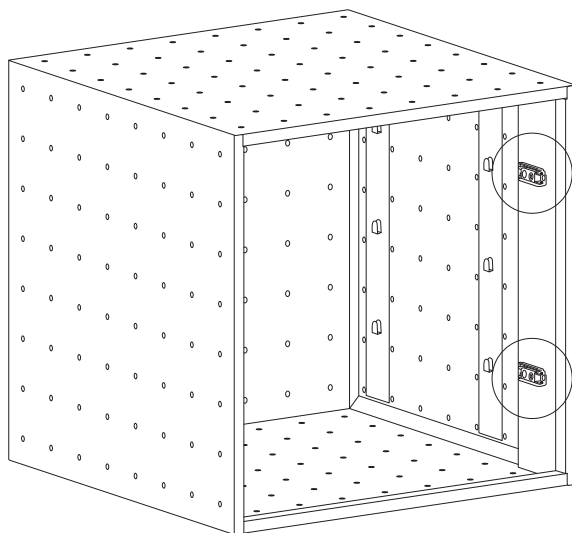

2

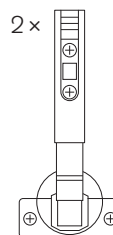
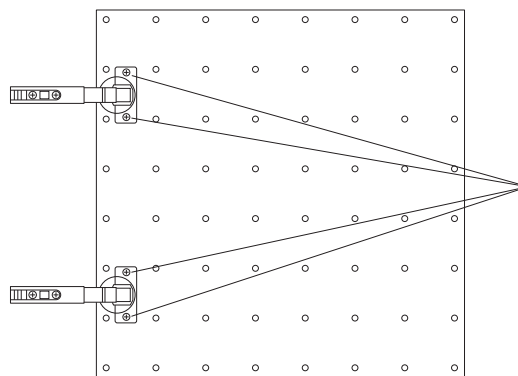

3

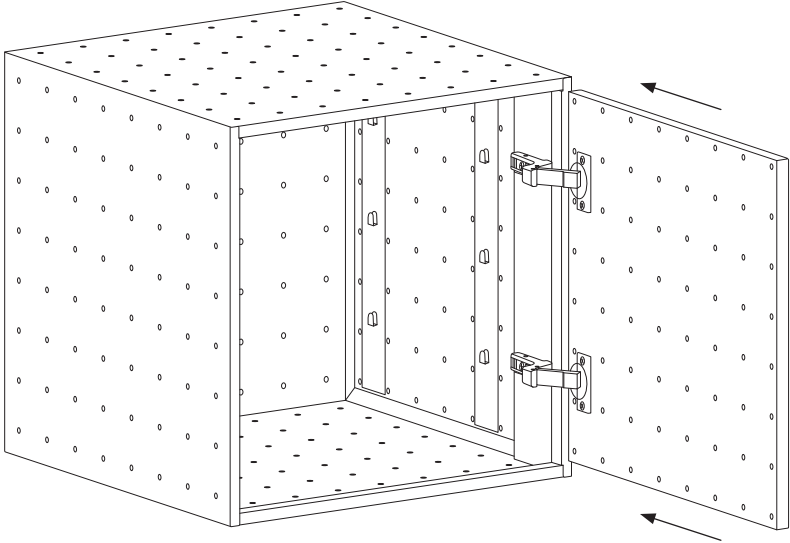

4

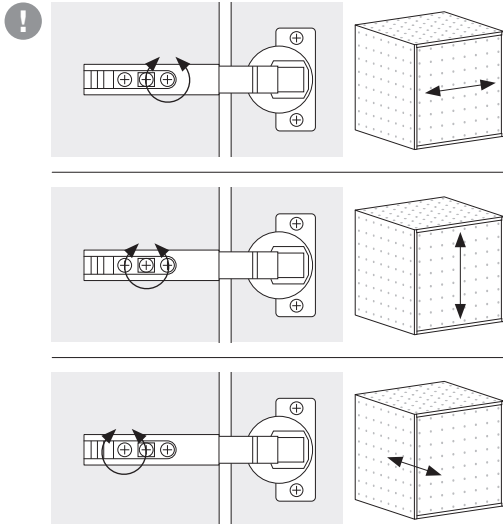

4

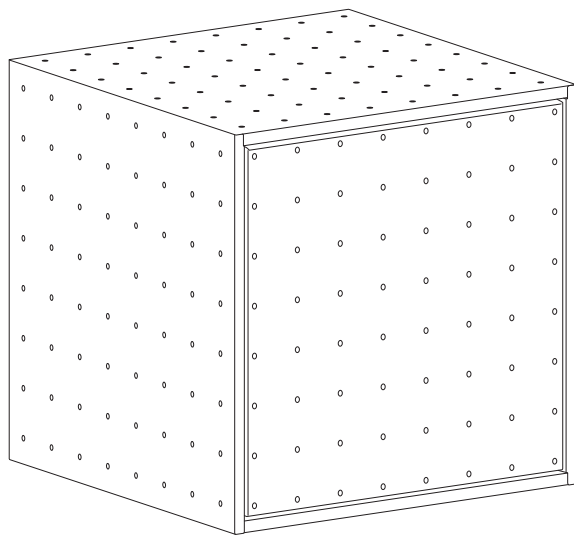

Assemble push opener
プッシュオープナーの取り付け

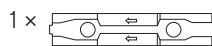

1

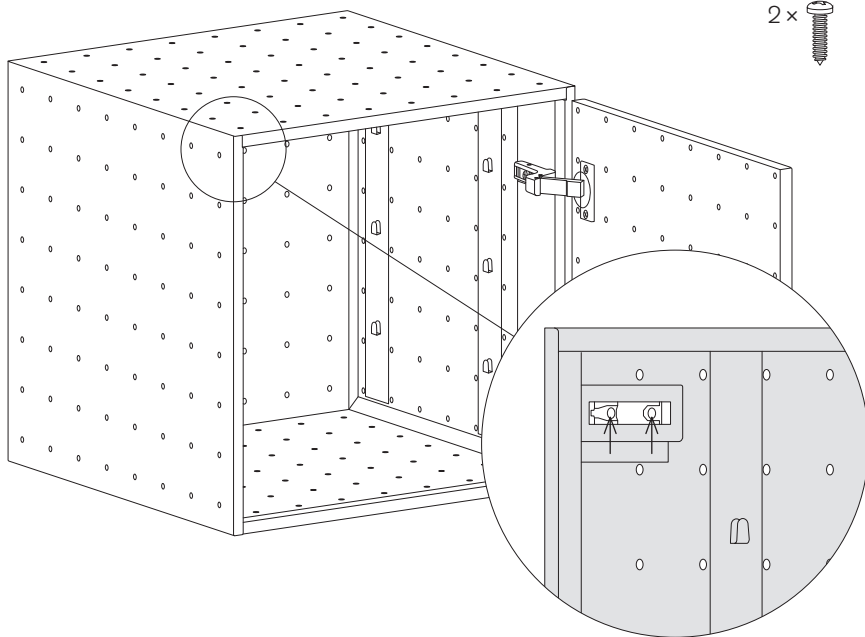

2

1 × 



3

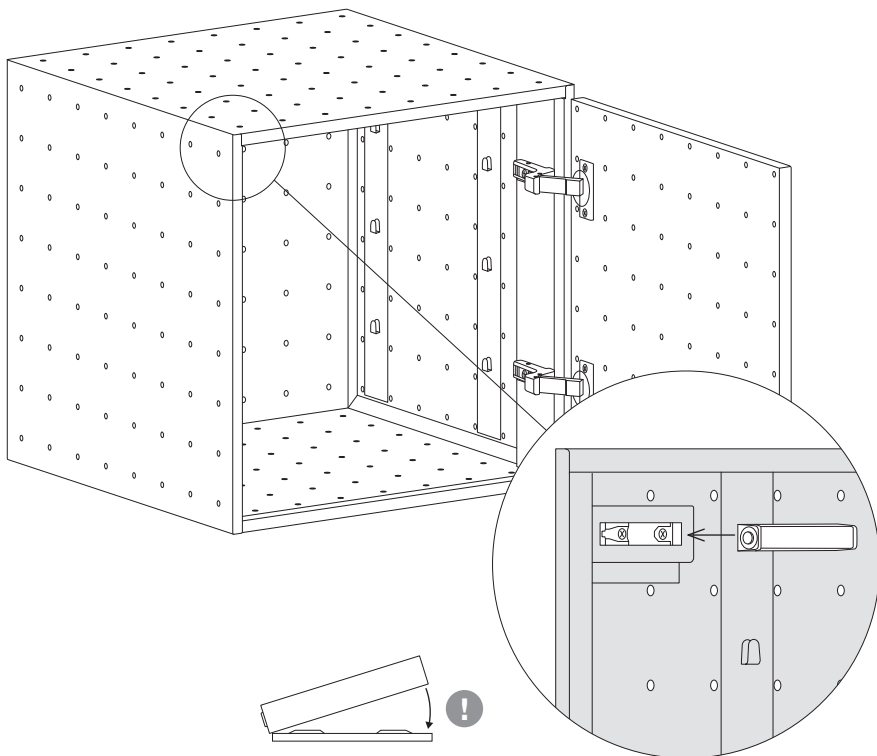

Assemble shelf
シェルフの設置

1

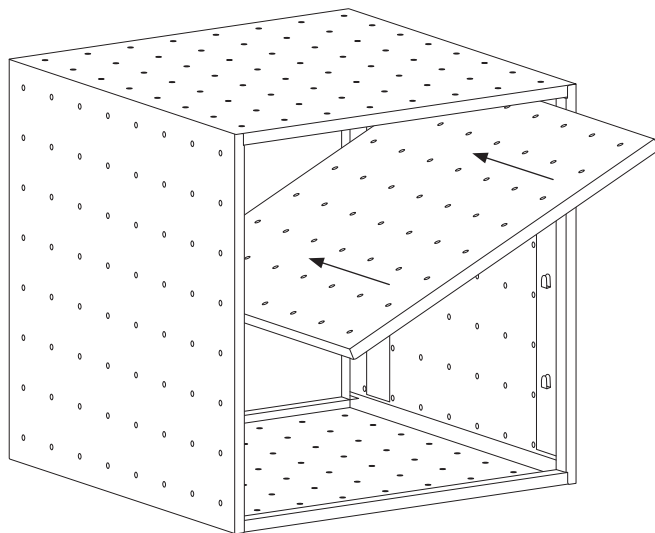

2

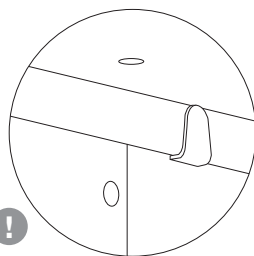
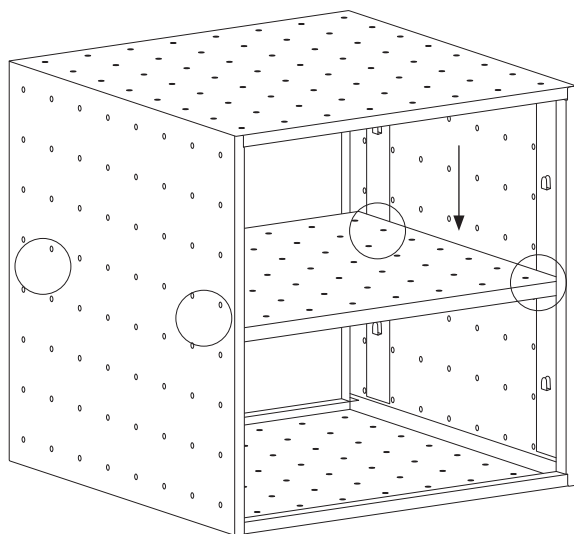

3

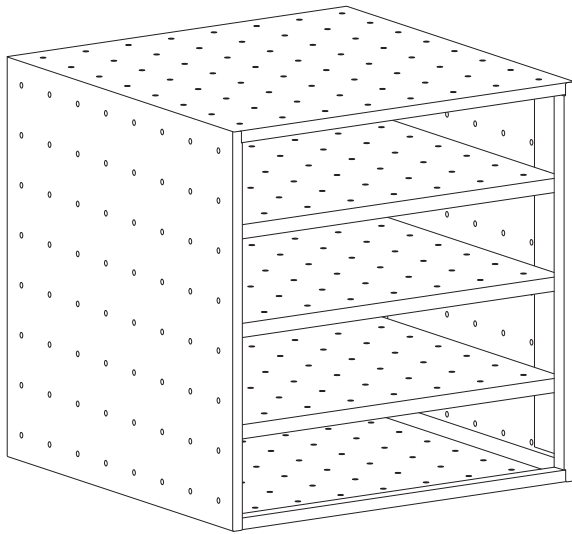

Assemble leg
レッグの取り付け

1

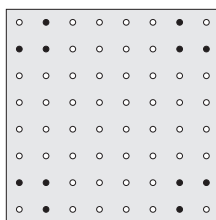
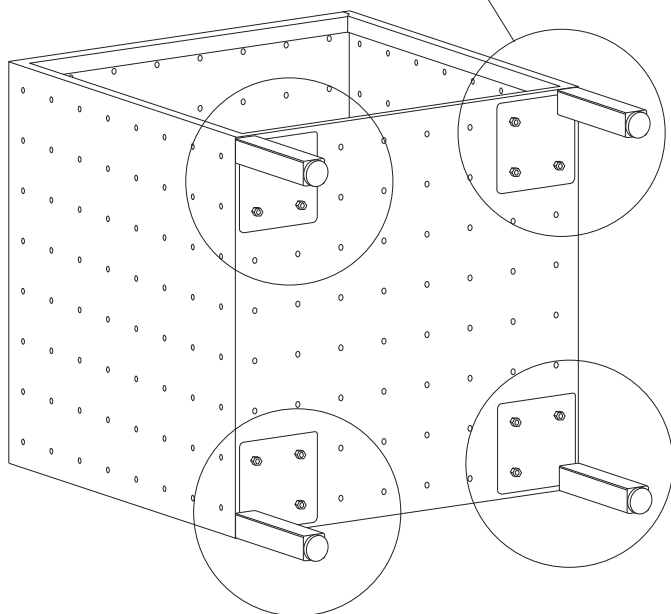
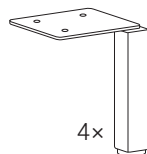
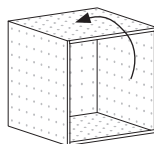
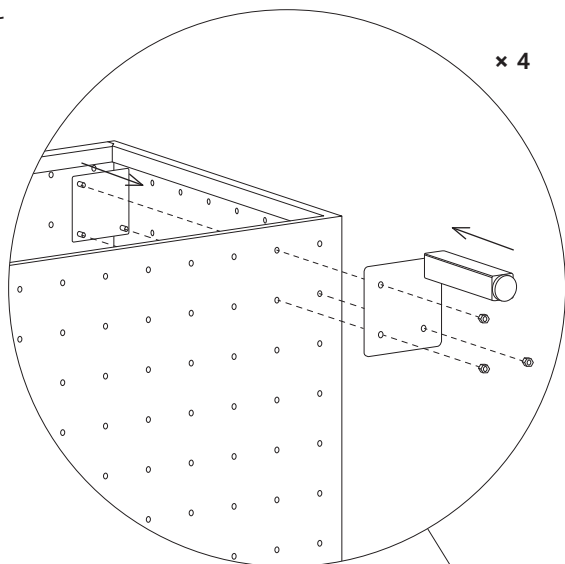

2

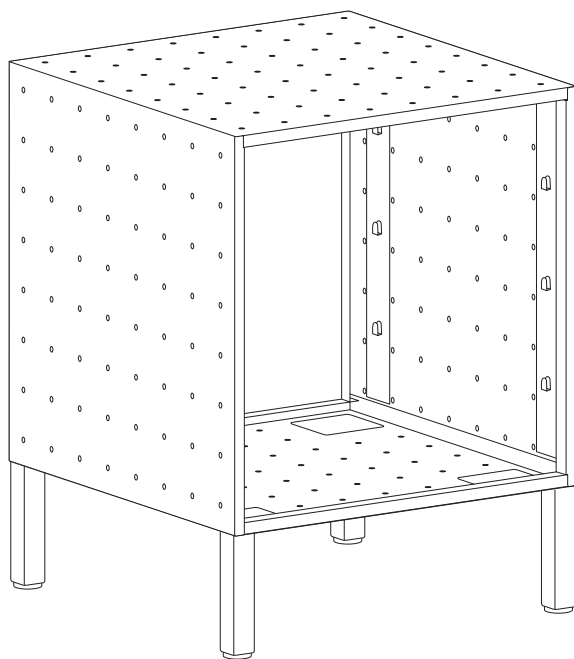
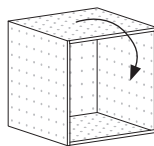

Assemble connecting leg コネクティングレッグの取り付け

1

× 2

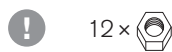
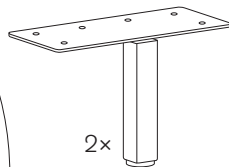
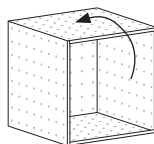
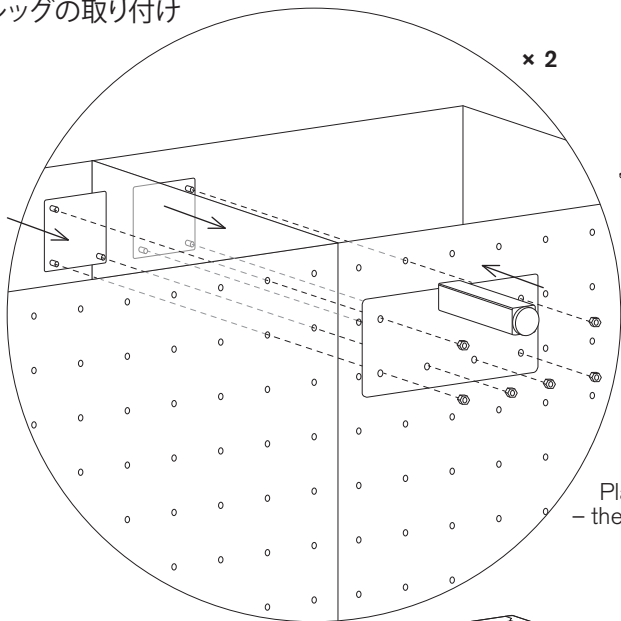

Place all
- then tighten

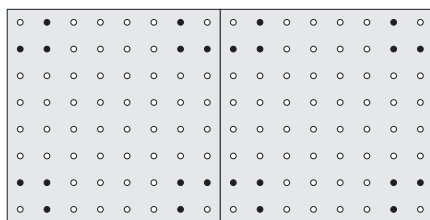
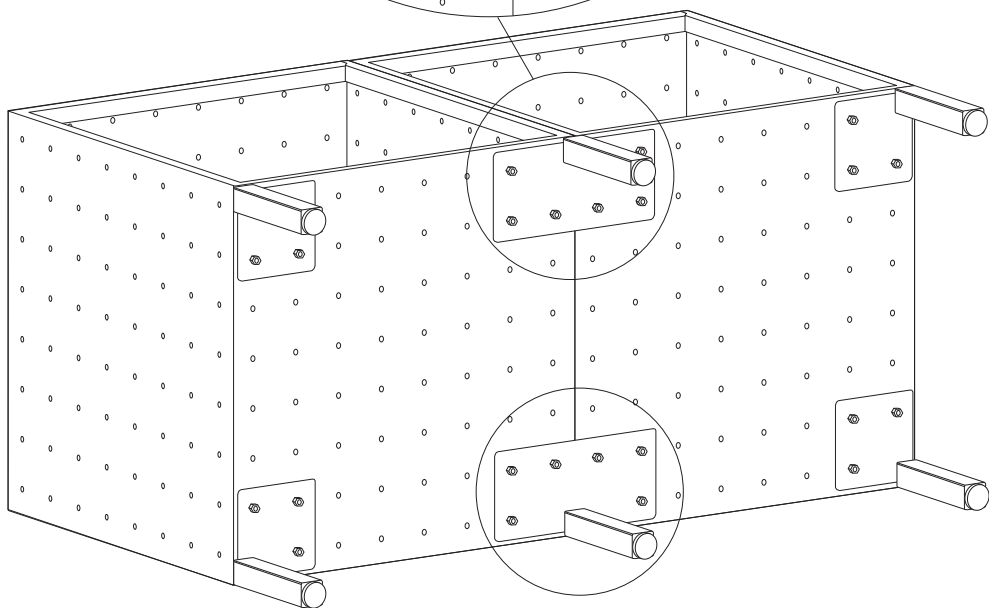

2

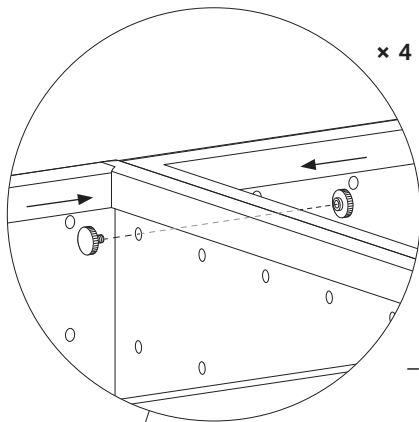
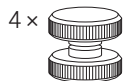

! Place all - then tighten

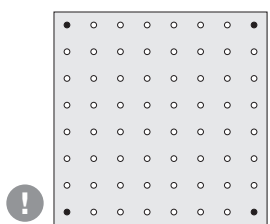
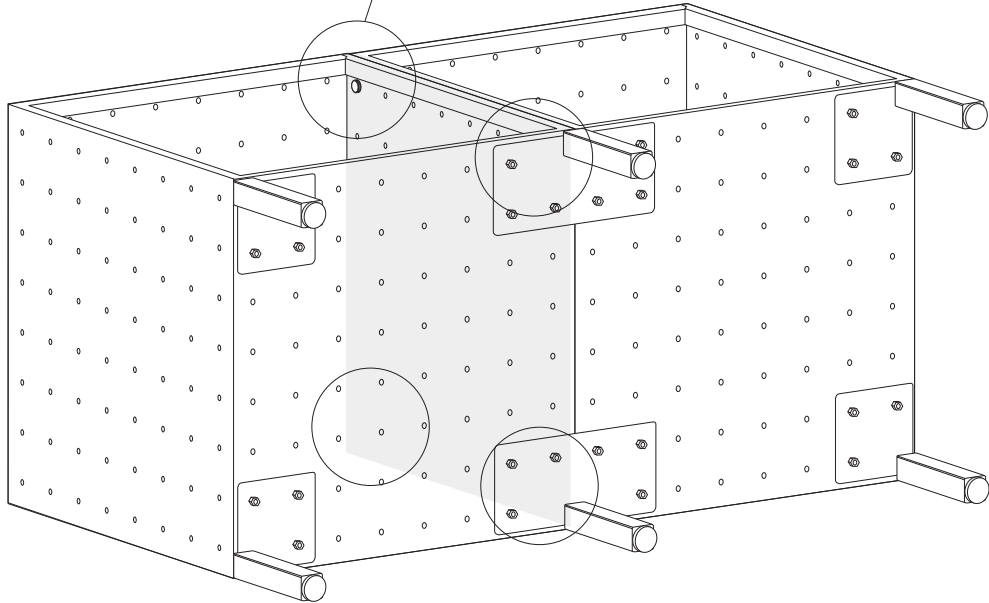

3

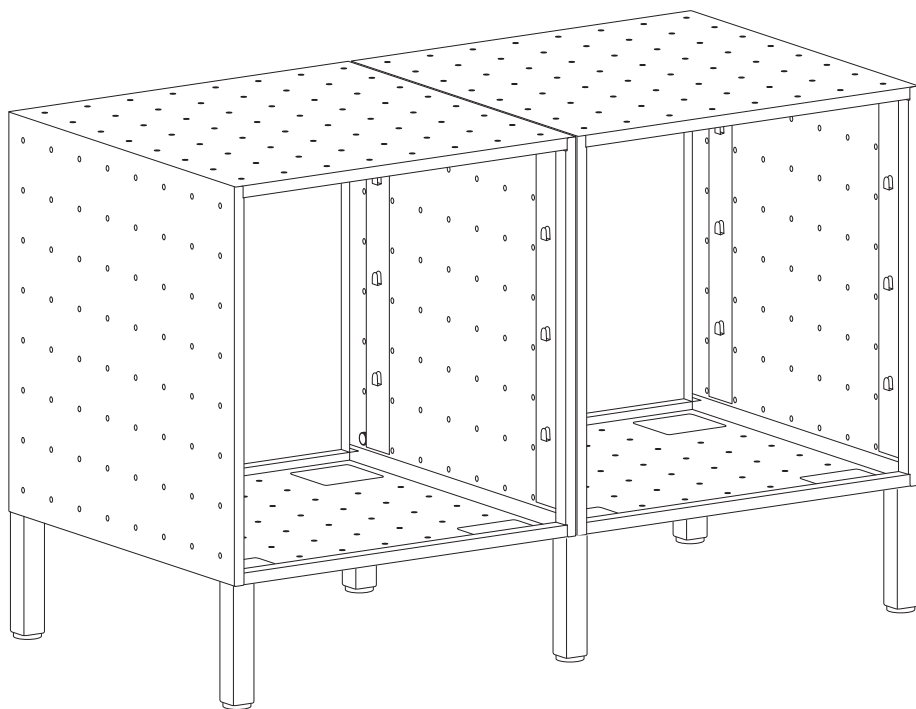
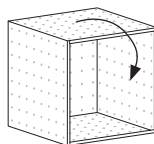

Assemble wheel
キャスターの取り付け

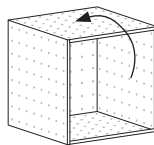
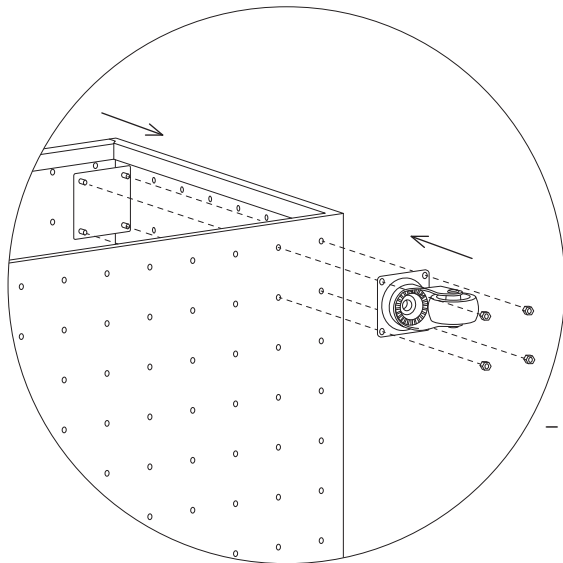

! Place all
- then tighten

Assemble connecting wheel
コネクティングキャスターの取り付け

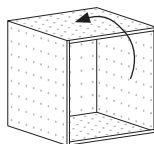
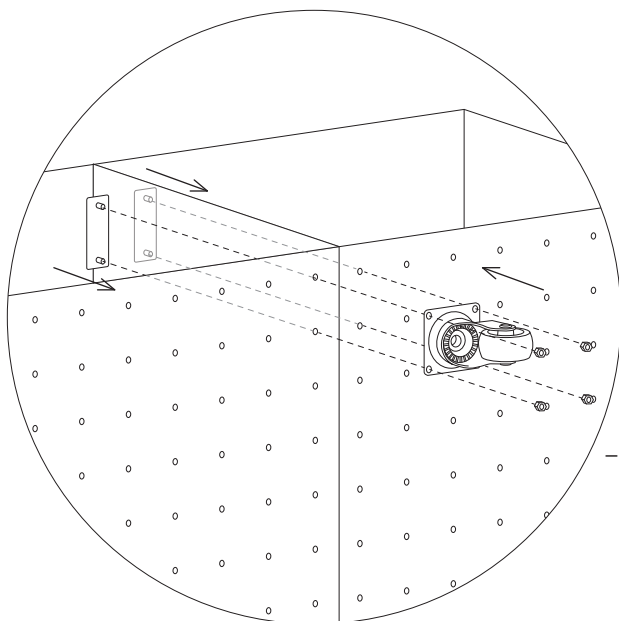

! Place all
- then tighten

Option

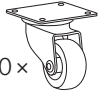

10 x



4 x



12 x



40 x

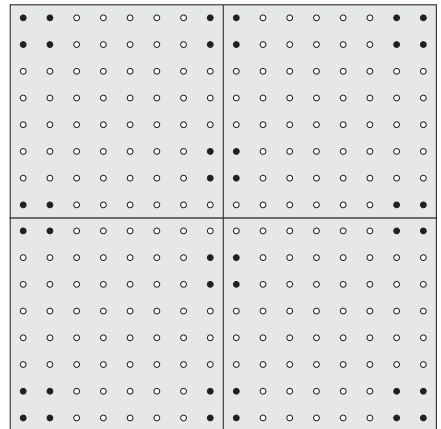
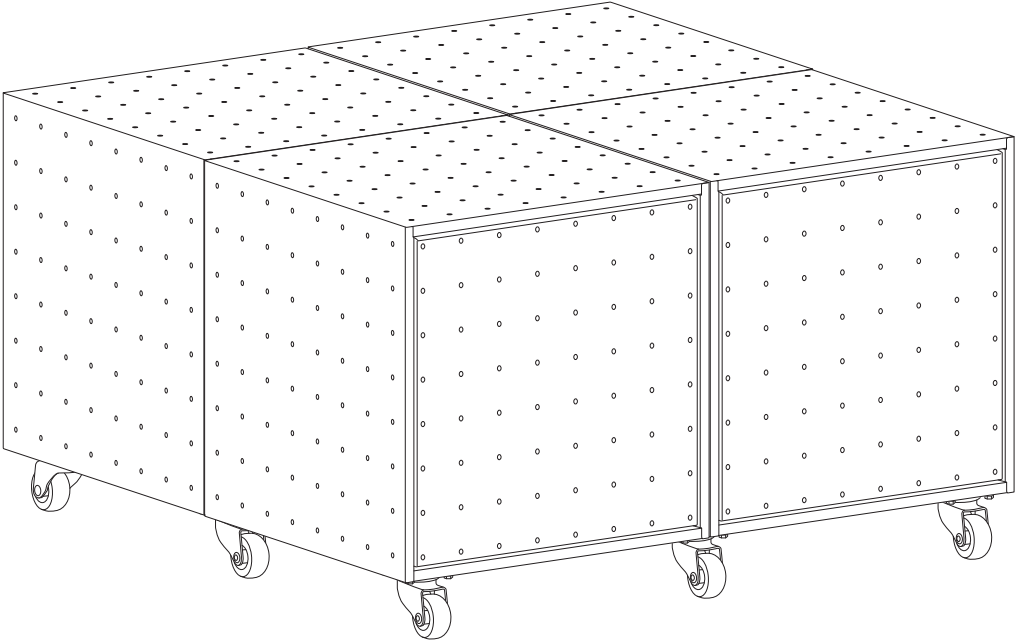

Assemble rubber pads
ラバーパッドの取り付け

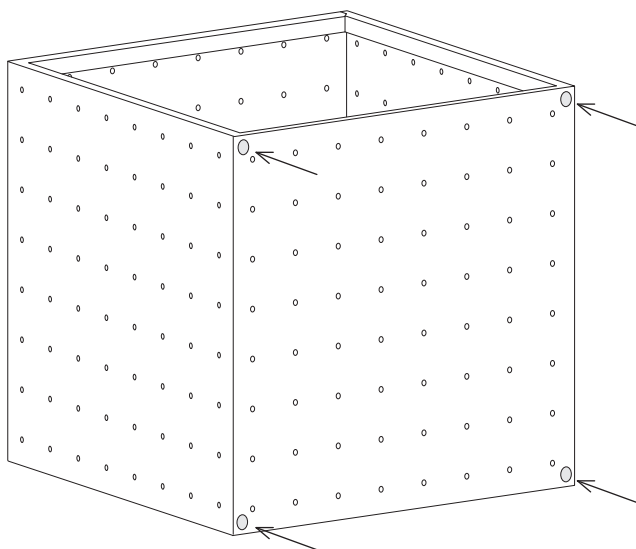
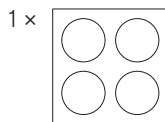
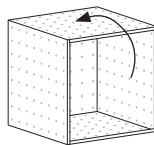

Assemble U-handle
Uハンドルの取り付け

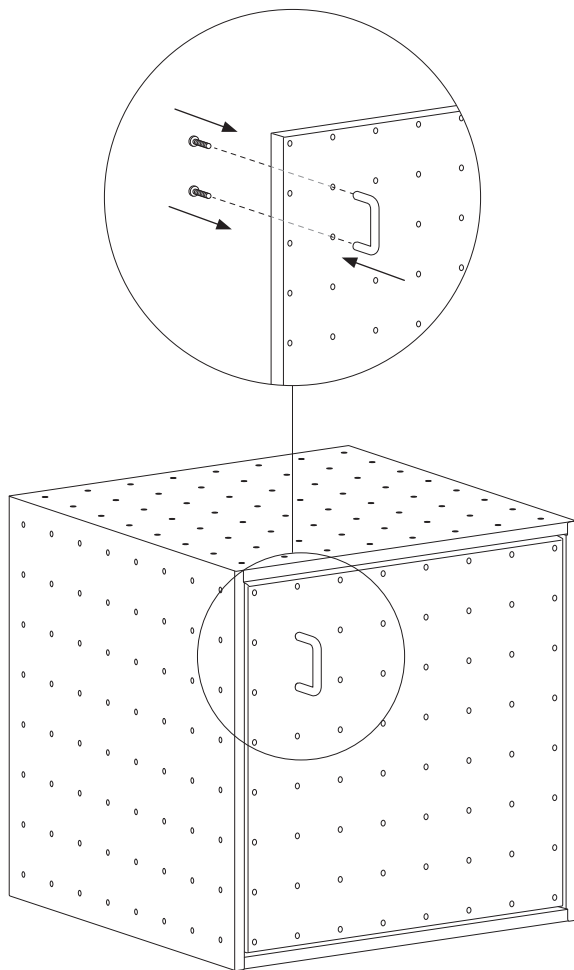

Assemble hook
フックの取り付け

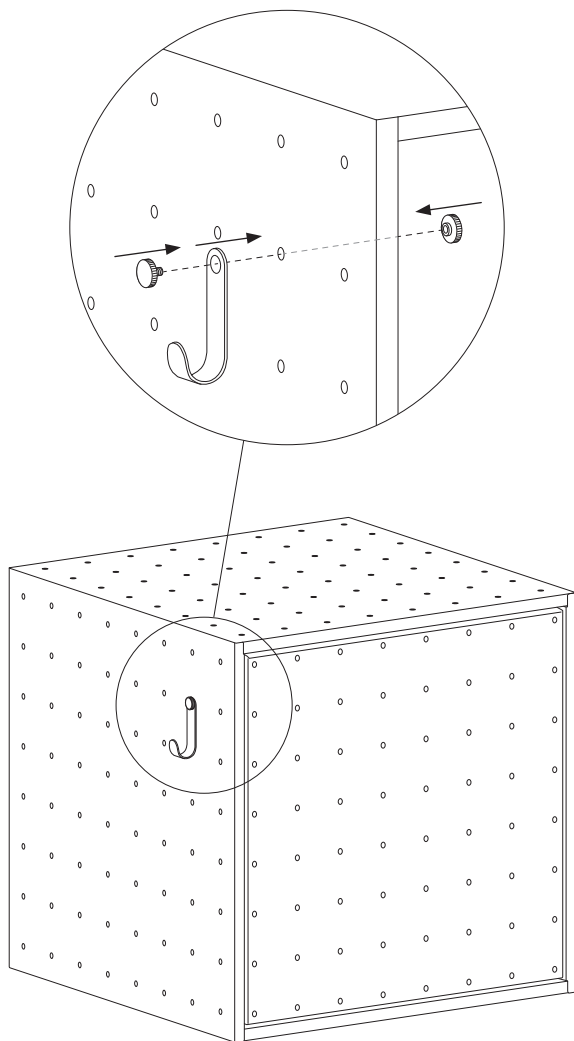
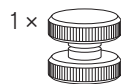

Assemble external shelf エクスターナルシェルフの取り付け

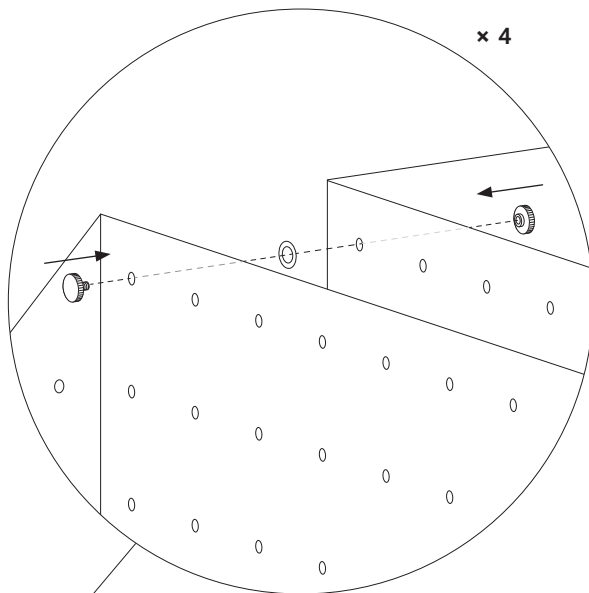

!
Place all
- then tighten

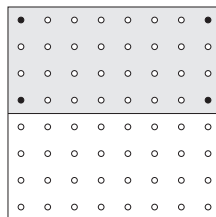
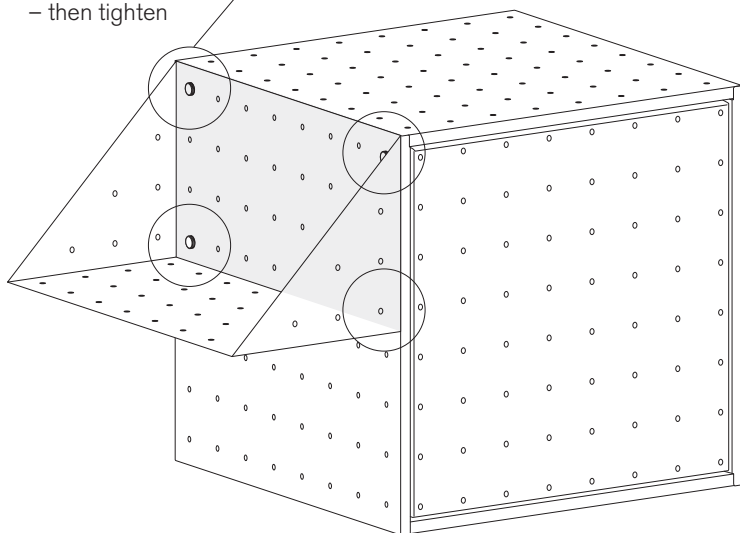

Assemble tray トレイの取り付け

1

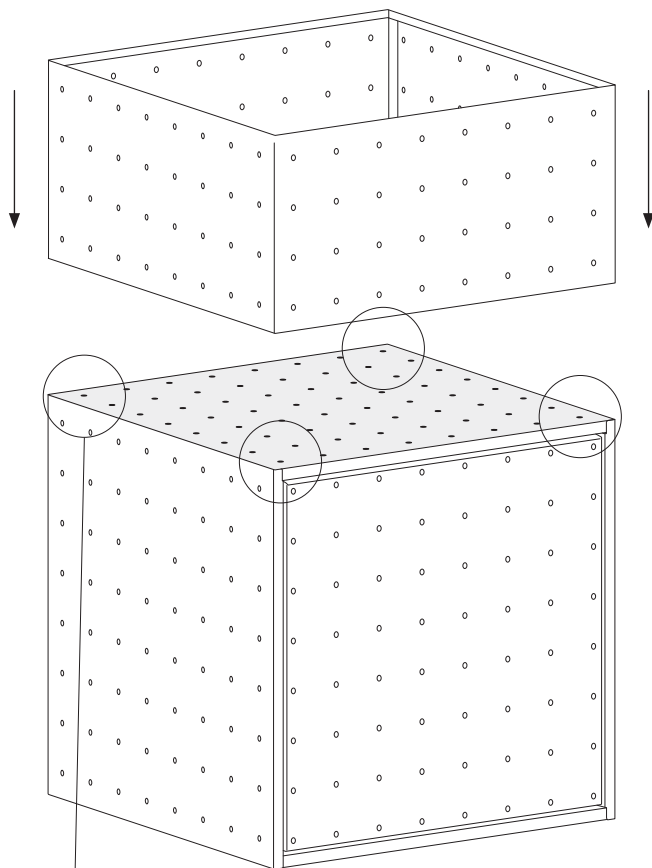

! Place all
- then tighten

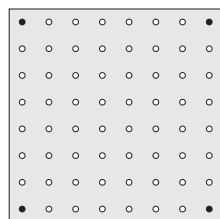
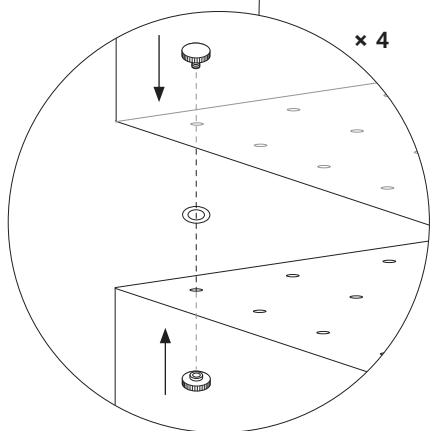

2

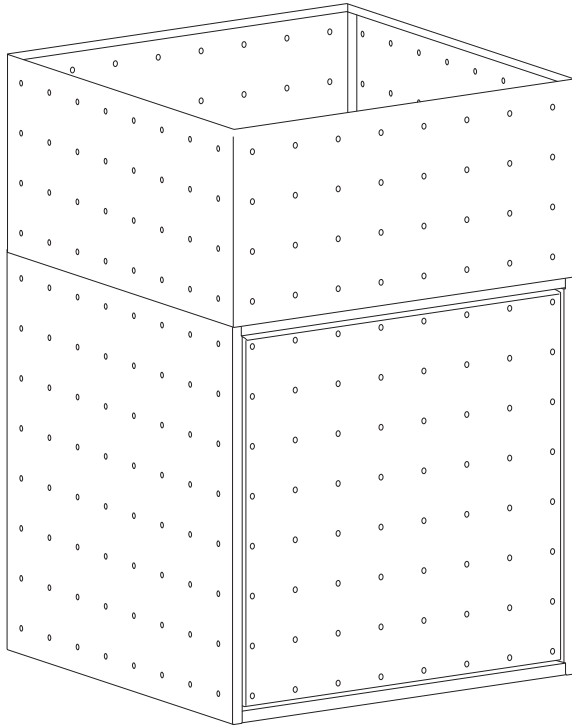

Connect modules – example
モジュールの連結方法

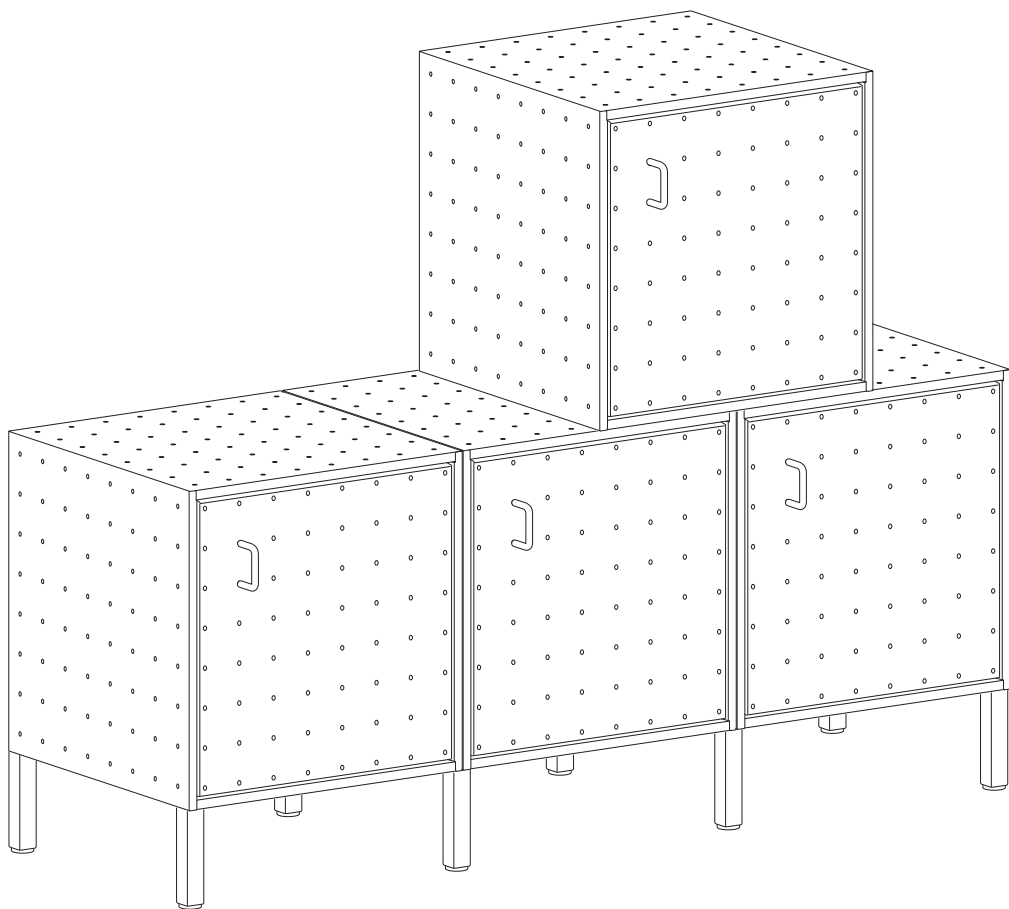

1

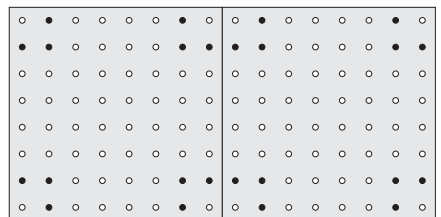
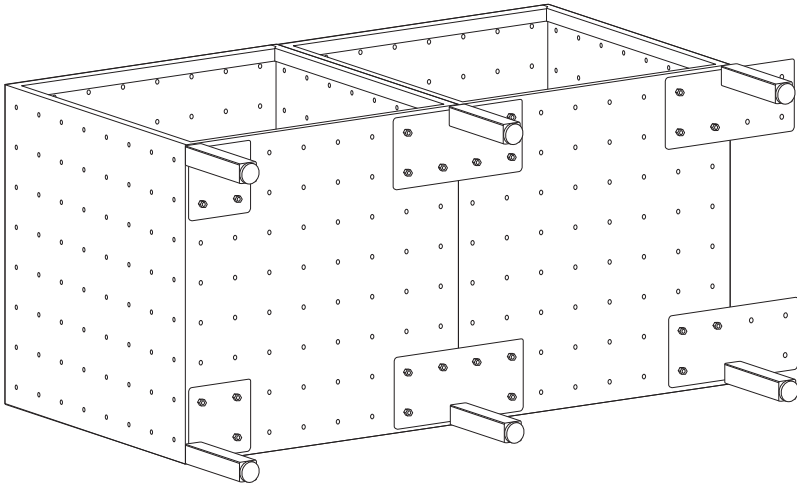
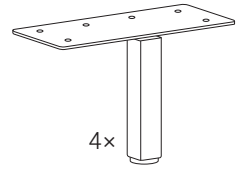
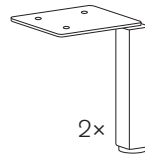
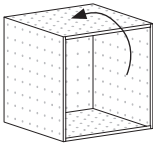

2

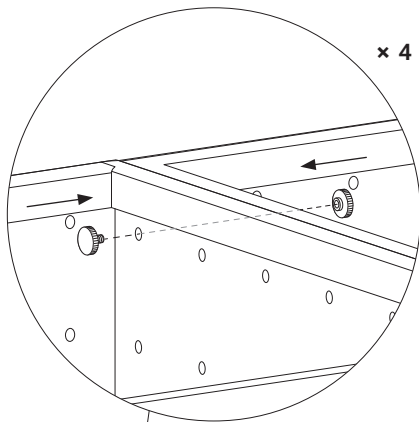

! Place all - then tighten

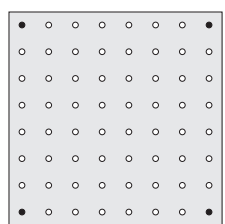
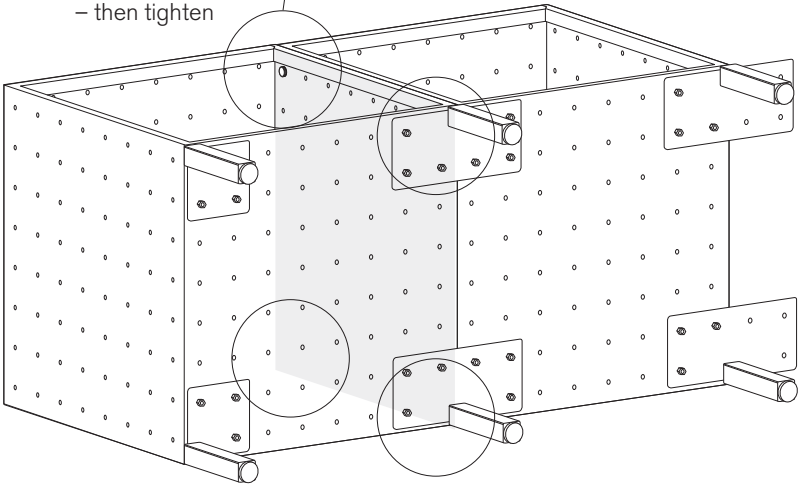

3

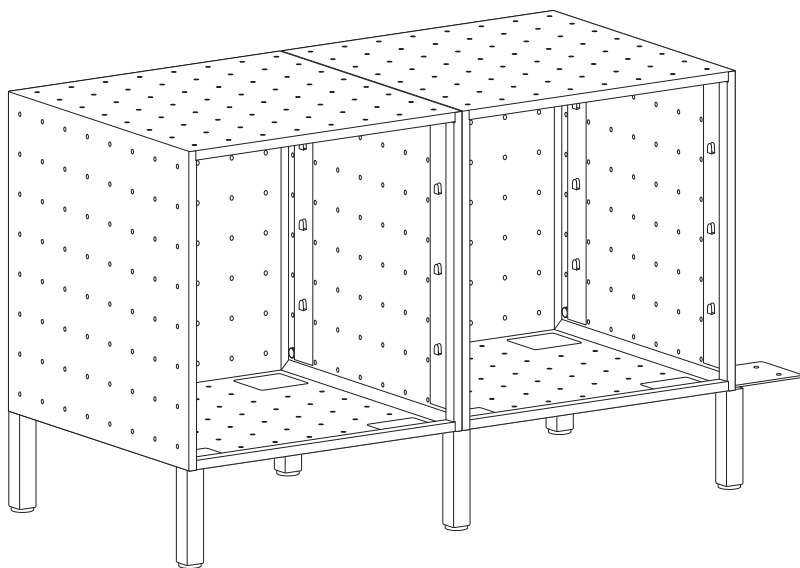
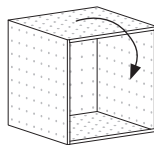

4

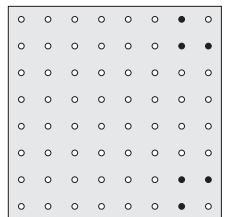
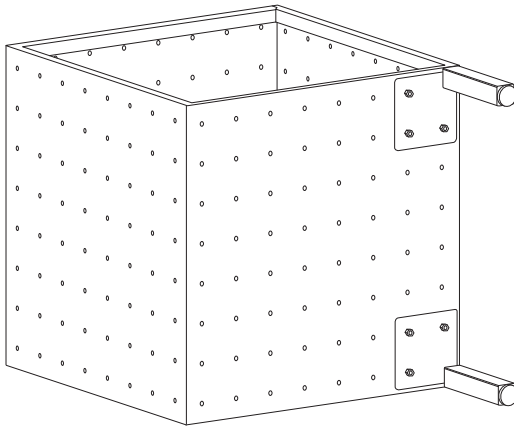
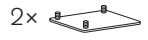
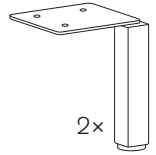
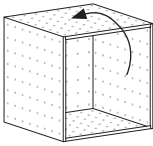

5

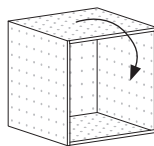

6 × 

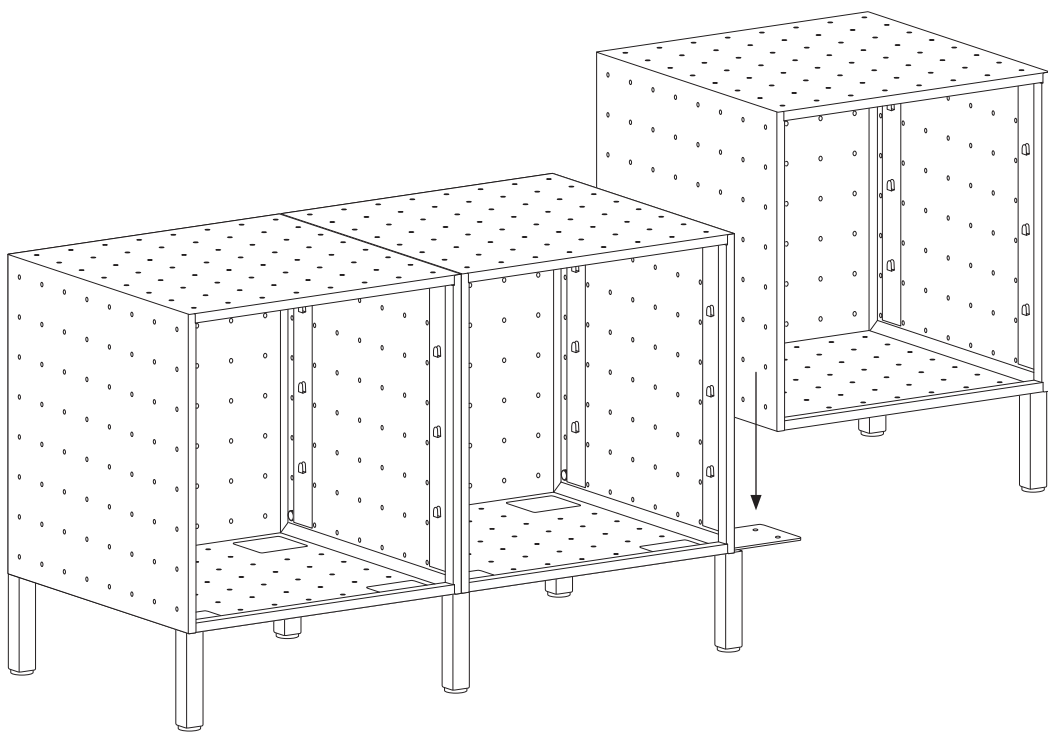

6

4 × 

Place all
- then tighten

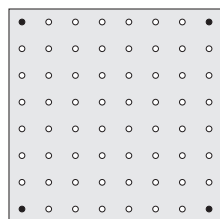
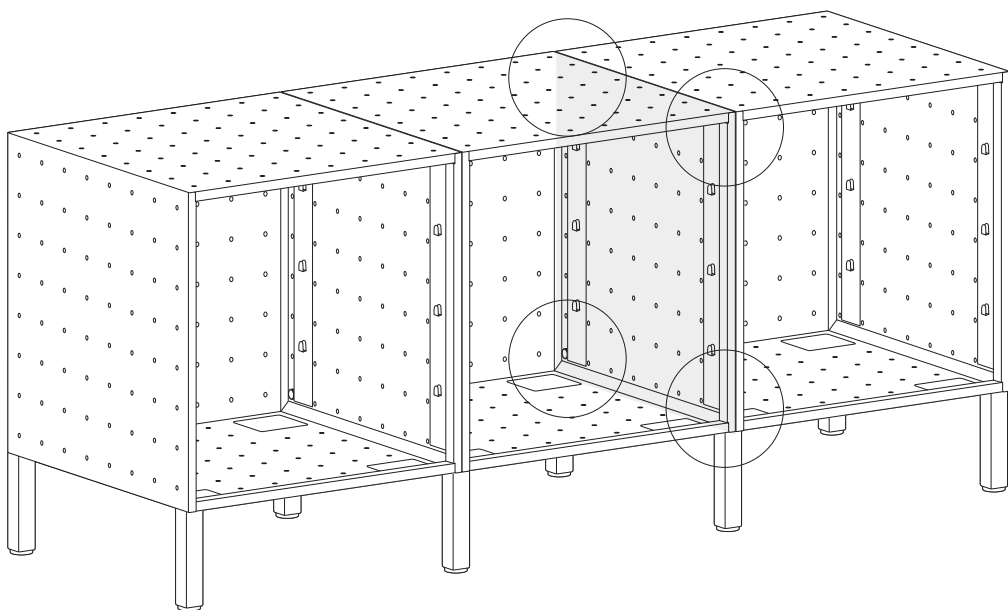

7

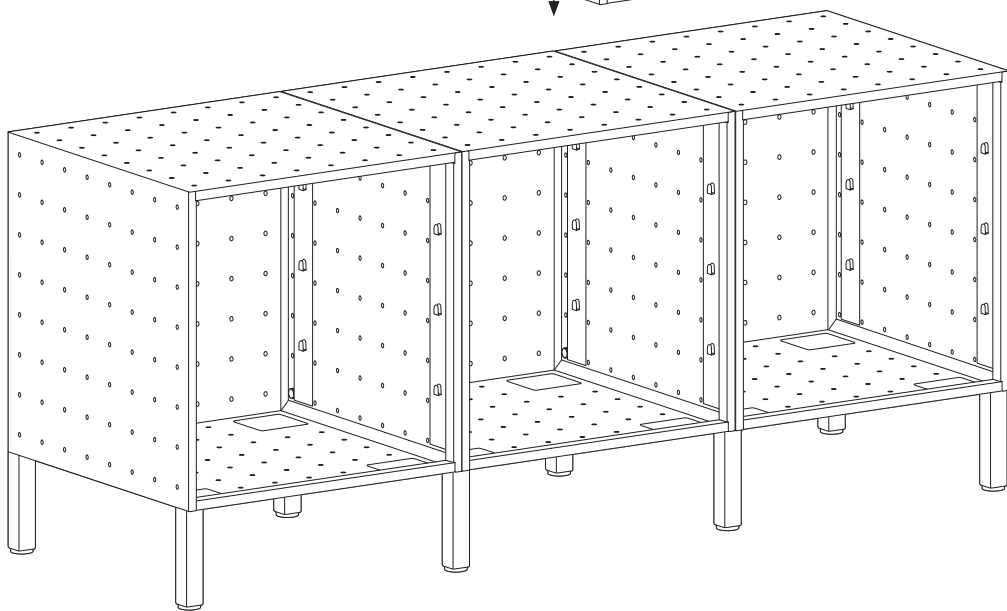
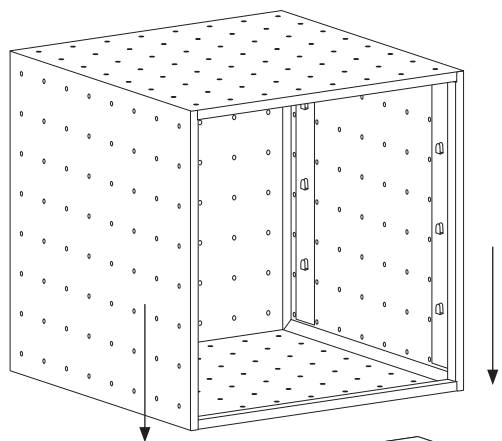

8

4 × 

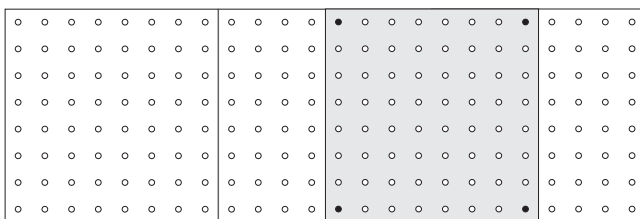
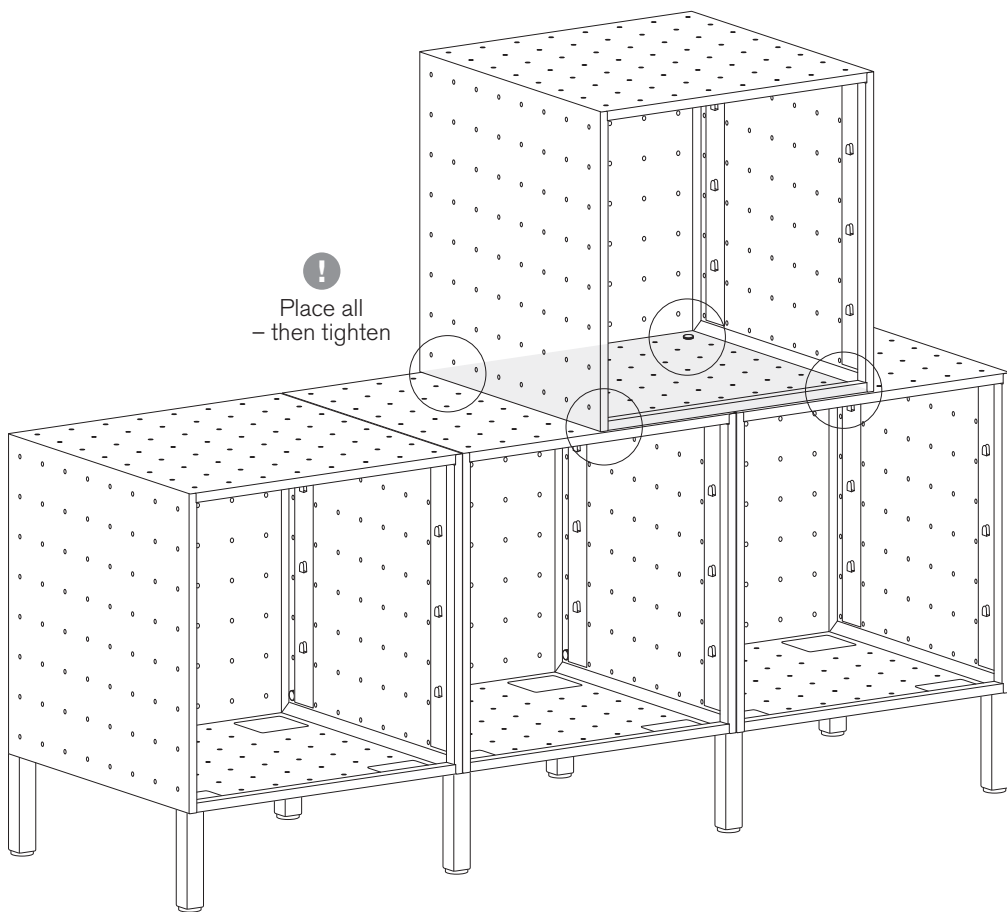

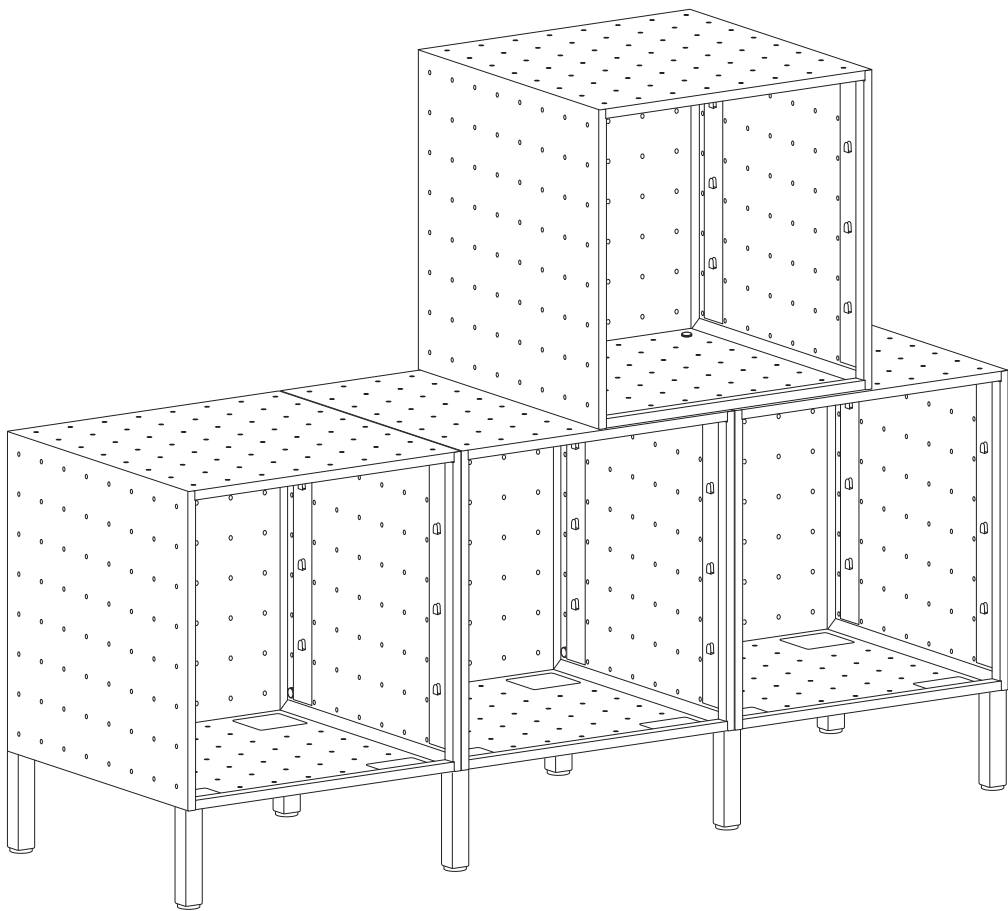

Anti-tip kit 転倒防止

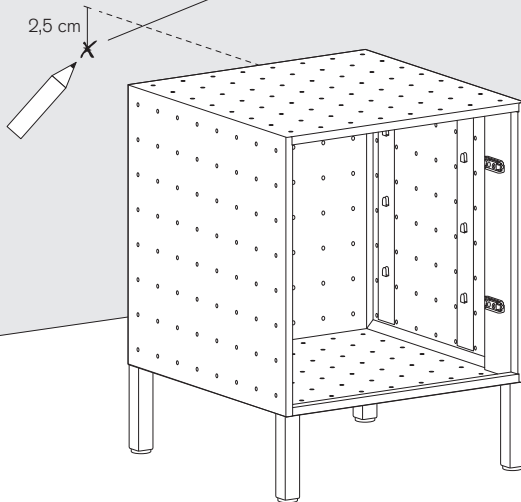
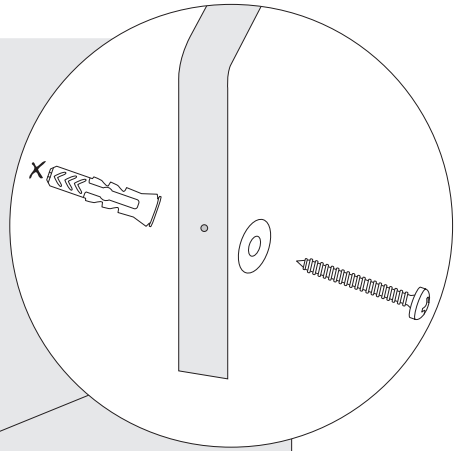
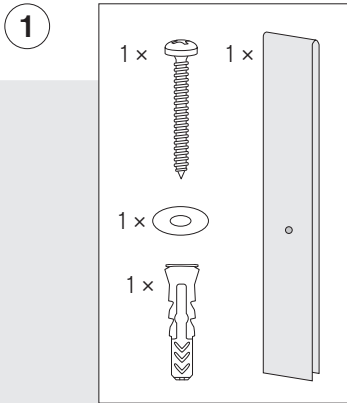
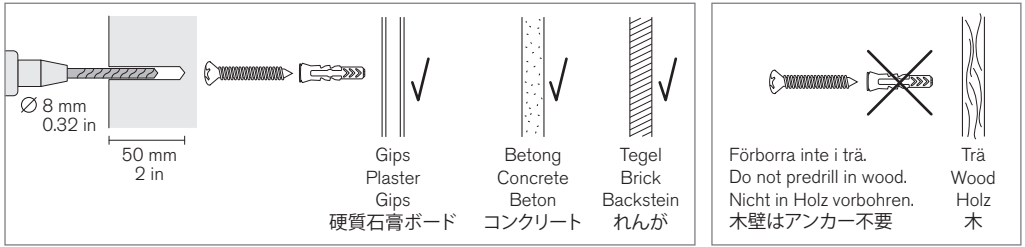

2

1 × 

2 × 

1 × 

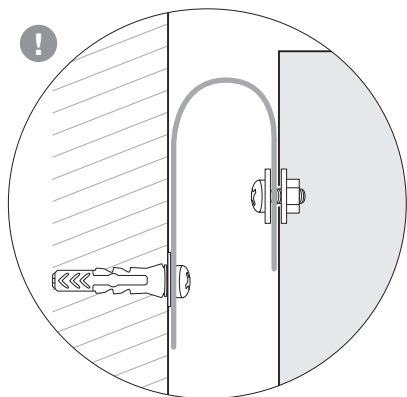
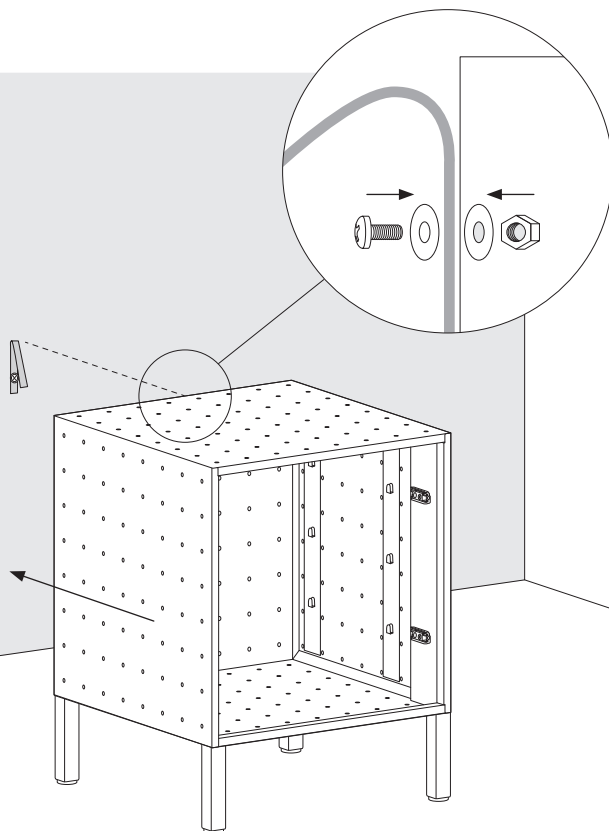

Option

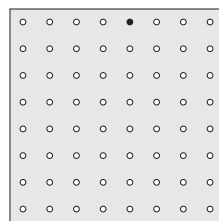
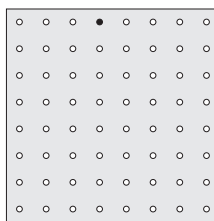

Wall mount kit 壁付け

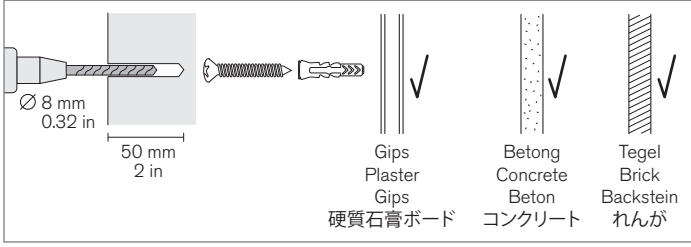

Ø 8 mm
0.32 in
50 mm
2 in

Gips
Plaster
Gips
硬質石膏ボード

Betong
Concrete
Beton
コンクリート

Tegel
Brick
Backstein
れんが

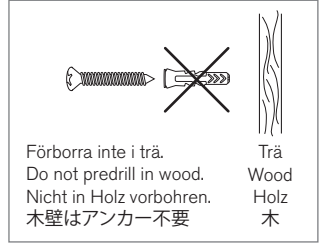

Förborra inte i trä.
Do not predrill in wood.
Nicht in Holz vorbohren.
木壁はアンカー不要

Trä
Wood
Holz
木

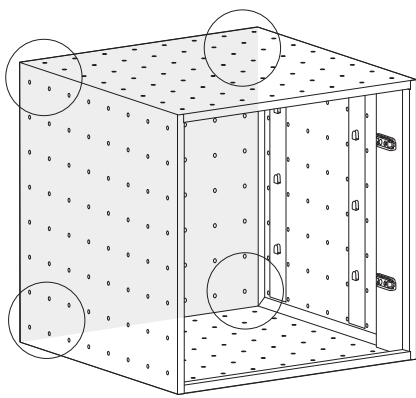

- 4 x 
- 4 x 
- 4 x 

